



# The Mabuchi Group The 2019 Social & Environmental Report

*Actuating Your Dreams*



ID-659ZA



IS-92BZC

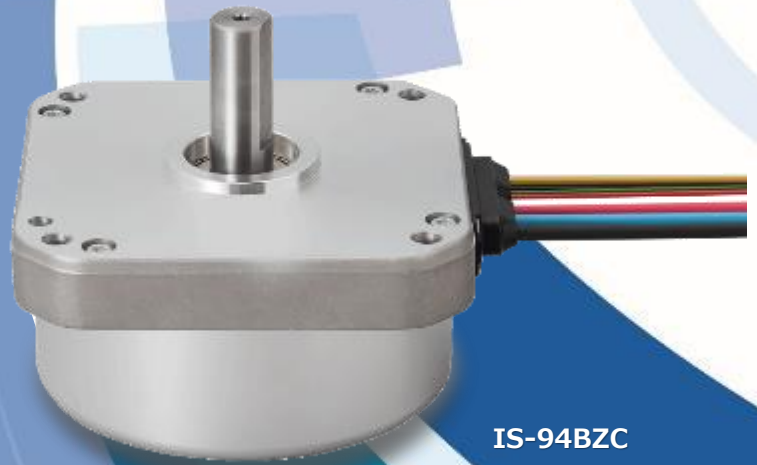

IS-94BZC

# The Mabuchi Group

## The 2019 Social & Environmental Report

### Editorial Policy

As a corporate citizen, Mabuchi Group will continue to be fully accountable for our CSR approach and the results of our activities through the publication of this Report. Also, we will further improve communication with all stakeholders and commit to making our future activities better.

This Report is no longer offered in hard copy but is available in digital form (PDF format) in light of environmental concerns.

### CONTENTS

Corporate Outline	2
CEO Message	3
Corporate Activities for Society and the Environment	5
Corporate Governance	8
Compliance	9
Risk Management	10
Supporting Local Communities	12
Support for Manufacturing/Education	13
Creating Lively Workplaces	15
Environmental Management	17
Green Procurement	18
Environmental Communication	19

**Period covered:** Fiscal 2018; Jan. 1, 2018 - Dec. 31, 2018 (For those outside the period, separately enter the date)

**Activities covered:** Details of environmental and social activities related to the design, manufacture, and sales of motors and provision of services

**Scope:** The Mabuchi Group

#### Japan

Mabuchi Motor Co., Ltd. (Head Office)

#### North and Latin America

Mabuchi Motor America Corp. (America Mabuchi)

Mabuchi Motor Mexico S.A.DE.C.V. (Mexico Mabuchi)

#### Europe

Mabuchi Motor (Europe) GmbH (Mabuchi Motor Europe)

Mabuchi Motor Poland sp. z o. o. (Poland Mabuchi)

#### Asia Pacific

Mabuchi Taiwan Co., Ltd. (Taiwan Mabuchi)

Mabuchi Motor Taiwan Ltd. (Kaohsiung Mabuchi)

Mabuchi Motor Vietnam Ltd. (Vietnam Mabuchi)

Mabuchi Motor Danang Ltd. (Danang Mabuchi)

Mabuchi Motor (Singapore) Pte. Ltd. (Singapore Mabuchi)

Mabuchi Motor Korea Co., Ltd. (Korea Mabuchi)

Mabuchi Motor Thailand Co., Ltd. (Thai Mabuchi)

#### China, Hong Kong

Mabuchi Industry Co., Ltd. (Hong Kong Mabuchi)

Mabuchi Motor (Dongguan) Co., Ltd. (Dongguan Mabuchi)

Mabuchi Precision (Dongguan) Co., Ltd. (Ludong Mabuchi)

Mabuchi Motor Dongguan Daojiao Co., Ltd. (Daojiao Mabuchi)

Mabuchi Motor (Jiangxi) Co., Ltd. (Jiangxi Mabuchi)

Mabuchi Motor Dalian Co., Ltd. (Dalian Mabuchi)

Mabuchi Motor Wafangdian Co., Ltd. (Wafangdian Mabuchi)

Mabuchi Motor (Jiangsu) Co., Ltd. (Jiangsu Mabuchi)

Mabuchi Motor (Shanghai) Co., Ltd. (Shanghai Mabuchi)

Mabuchi Motor Trading (Shenzhen) Co., Ltd. (Shenzhen Mabuchi)

## Management Principle

“Contributing to international society and continuously increasing our contribution.”

### Management Guidelines

1. By bringing better and more reasonably priced goods to the market, we contribute to the creation of a more affluent society and more comfortable lives for everyone.
2. Contribute to eliminating international economic disparities and to economic development in other countries through the creation of employment opportunities and technology transfers.
3. People are the most important managerial resource.
4. Conduct corporate activities which preserve the earth's environment and protect human health.

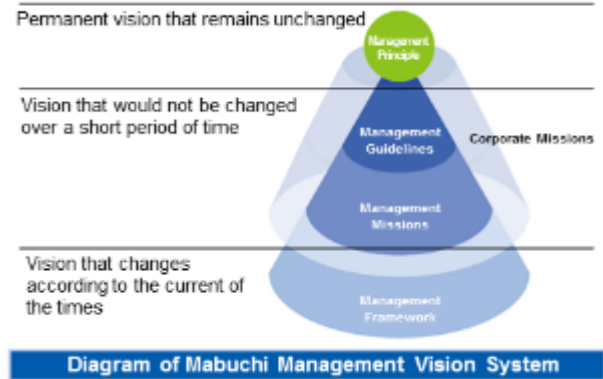

## Company Profile

<b>Trade name</b>	Mabuchi Motor Co., Ltd. MABUCHI MOTOR CO.,LTD.
<b>Date of establishment</b>	January 18, 1954
<b>Contents of operations</b>	Manufacture and sale of small electric motors
<b>Capital</b>	20,704.81 million yen
<b>President</b>	President and Representative Director, CEO Hiroo Okoshi
<b>Employees</b>	Head Office: 824; Mabuchi Group: 23,476 (as of Dec. 31, 2018)

<b>Consolidated Business Results</b>	Net sales: 143,160 million yen Operating income: 21,243 million yen Net income: 22,925 million yen (FY2018 ended Dec. 31)
<b>Location (Head Office)</b>	430 Matsuhidai, Matsudo-shi, Chiba-ken, 270-2280 Japan Tel.: +81-47-710-1111(main) (Technical Research Institute) 280 Ryufukuji, Inzai-shi, Chiba-ken, 270-2293 Japan Tel.: +81-47-710-1222 (main)

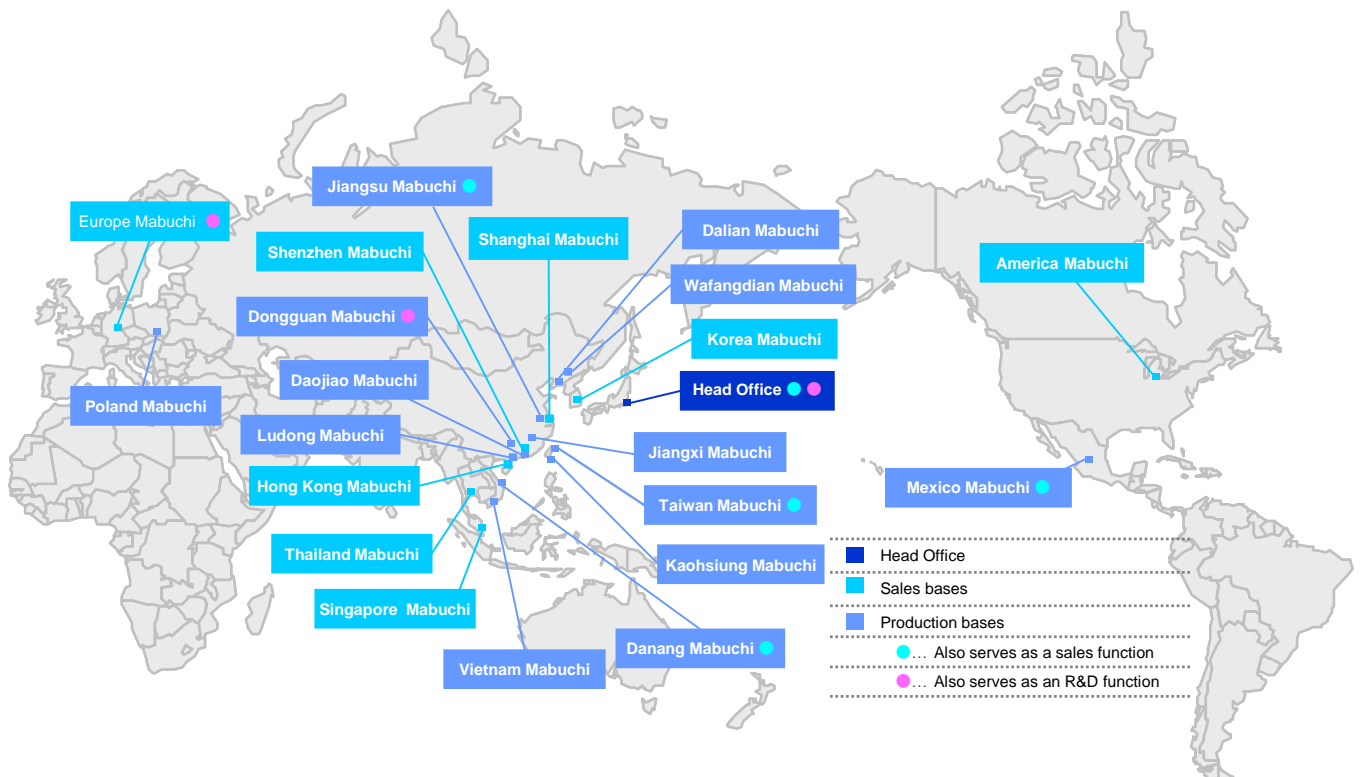



# CEO MESSAGE

## Contribute to the creation of a sustainable society through business

Mabuchi Motor was established in 1954 with the wish of enabling children around the world to enjoy high-quality and low-cost motivity. The market has changed drastically in line with the subsequent technological innovation and globalization progress, the market for automotive equipment applications now account for more than 70% of sales.

Even with the 65th anniversary of our founding, our mission as a professional manufacturer is to provide better products cheaper and more stable, and to help people's life become convenient, comfort and safe.

By thoroughly pursuing the potential of motors, refining their values, and enabling customers to make their products smaller, lighter, and to achieve energy saving, we will contribute to resource and energy saving throughout society.

In order to realize the SDGs (sustainable development goals) set forth by the 193 member states of the United Nations, we must not only recognize the issues, but also create values to solve the issues. This value creation is the very concept of the Management Philosophy "Contribution to the international community", which is a fundamental idea that goes through all the activities of the Mabuchi Group.

"Contribution to the international community", we think, means "true globalization", where we contribute to local communities by cultivating technology and human resources, and developing the economy with the people of that country and region.

All employees of the Mabuchi Group are working on daily activities with altruistic mind that companies exist to contribute to society and create happiness for people.



**Hiroo Okoshi**

**Representative Director and President CEO**

Through thorough "standardization", Mabuchi Group has achieved both high quality and low price by developing motors that are the greatest common factor for customer requests. We acquire standardized components and produce products using facilities fully equipped with automation technology near our clients around the world. This local procurement and local production system allows us to offer consistently high-quality motors anywhere in the world. This global standardization strategy is our strength. Since the launch of operations in Hong Kong in 1964, Mabuchi Motor has rolled out its overseas operations, aggressively building global production and supply systems in China, Taiwan, Vietnam, Mexico and Poland. We will take this initiative to a higher stage and realize more social contribution around the world. In addition, we are continuously conducting supporting education activities using motors. Children enjoy driving motors at

craft classes and visit classes, and students working hard with great ideas in robot contests. Their future growth is our great pleasure. People are creators of societies, and it will be extremely important issue for international society to foster and train the next generation of engineers. By offering educational opportunities for people to experience our motors and "technologies" used for the motors as well as "manufacturing", we do and will keep making a commitment to fostering people who will play leading roles in the future.

With our unchanged management principle, we are going to actively work on solving problems through our business operations with various stakeholders. We would appreciate your continued support.



As the world's No. 1 brand with an annual production volume of approximately 1.5 billion units, Mabuchi Group is active in a wide range of applications, achieving environmentally-friendly, high-performance, low-cost, flexible production and supply.

# Corporate Activities for Society and the Environment

Mabuchi Group considers that SDGs (Sustainable Development Goals) can achieve an economic growth while cherishing people, and promotes positive social and environmental initiatives to achieve their goals.

## Sustainable Development Goals (SDGs)

SDGs unanimously adopted by 193 countries at the UN General Assembly in September 2015 have 17 goals to be achieved by 2030 and 169 targets to achieve each goal. This requires action from countries and people all over the world, as well as businesses.



## Environmental Considerations in Corporate Activities

### Power-Saving Efforts

We are working on company-wide power saving by promoting measures such as the replacement of existing lights on the premises with LED lights, strict management of air conditioner temperature settings, and summertime suspension of hot water supply and toilet seat heating. The progress of electric usage situation is checked by the General Affairs Department and posted on the company intranet and in the plants so as to increase awareness of the need for power saving.



Promoting replacement of existing lights with LED lights (Head office canteen)



LED lighting is adopted throughout (Poland Mabuchi)

### Improving convenience and energy saving of employee's lodgings

A shower room was newly installed inside the lodgings at Wafangdian Mabuchi. The new hot water system in this shower room controls power consumption by reusing waste heat (warm water).



Hot water tank circulation unit

### Efforts in Introduction of Production Equipment

Mabuchi group is also constantly working on environmentally friendly activities in the production process. For example, at the time of producing facility production, we conduct the following multifaceted environmental impact assessments and make plans for introducing production facility equipment:

1. Existence of banned substances
2. Usage volume of power, air, water, etc.
3. Fuel consumption
4. Emissions of air pollutants, ozone depleting substances and sewage
5. Vibration and noise level
6. Waste and hazardous material emissions to which the Industrial Safety and Health Act applies
7. Whether there is a possibility of toxic substance leakage at the time of equipment disposal
8. Presence or absence of instructions / explanation of harmful substance recovery - etc.

## Creating environmentally friendly products

We are contributing to resource and energy saving throughout society by supplying better products cheaper and more stable, making customers' final products smaller, lighter, and achieving energy shaving. We believe that it is the mission of a manufacturer specialized in motor to make people's lives convenient, comfortable and safe, and we thoroughly pursue the potential of motors and refine their values.



Mabuchi motor helps make your life convenient, comfortable and safe in various applications.

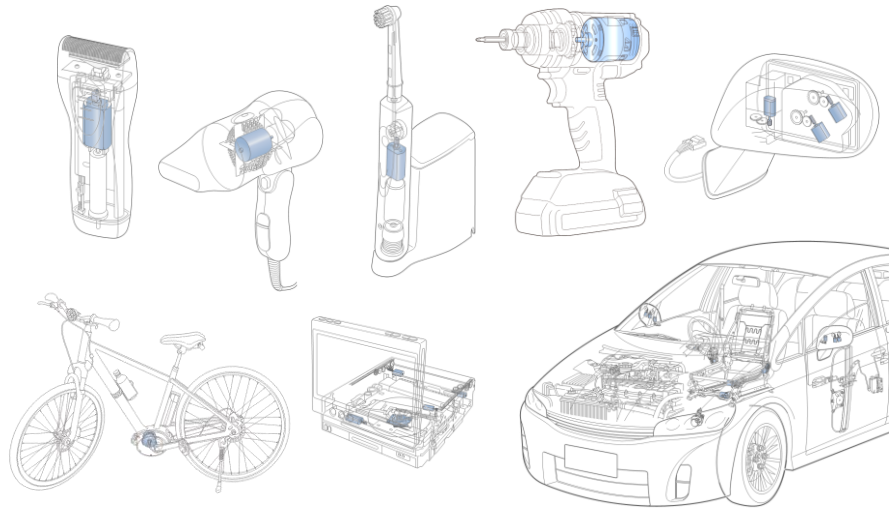

## New Product Lineup



Motors for peripheral engine equipment  
RS-4G5WA



RS-4G5WA

### [Typical Applications]

Engine air control valve/Engine coolant valve/Turbocharger actuator/EGR valve

Output	Approx. 2.0 – 33 (W)
Operating Voltage	8-16 (V)
Size	Diameter 28.8 – 46.5 (mm)
Weight	Approx. 125 (g)

We are also continuously striving for automobile electric motors that are higher in torque, smaller, and lighter in order to contribute to reducing the size, weight, and power consumption of our customers' final products, thereby conserving energy and resources across society.

The new product RS-4G5WA is adapted to the severe operating environment of an automotive engine periphery. Using it for electronic control of various valves contributes to improving fuel efficiency and reducing hazardous emissions.

### [Product features]

#### 1. Improved heat resistance

Uses heat resistant materials to adapt to the severe temperature environment (-40°C to 150°C) around the engine periphery.

#### 2. Improved vibration resistance

Improved strength to achieve vibration resistance equivalent to 40G sine wave vibration test.\*

#### 3. Conforms to electric noise standards

Adopted a structure capable of incorporating elements such as a choke coil and a capacitor to conform to electric noise standards.

#### 4. Compatible with high torque applications such as turbocharger applications

Contribute to miniaturization and weight reduction of periphery engine equipment products with superb torque characteristics.

\* A test applying periodic vibrations to determine performance deterioration and mechanical weak points.



## Brushless Motor ID-659ZA



ID-659ZA

New brushless motor ID-659D meets the recently increased needs of small size, light weight, high efficiency and power saving in the consumer and business equipment market.

### [Product features]

#### 1. Realization of reduction in size and weight, and high efficiency

Low vibration is realized by adopting IPM\* structure. Both reduction in size and weight, and high efficiency were achieved by optimizing magnet circuit.

#### 2. Built-in drive circuit that can adjust the number of rotations

Various operation modes can be supported by a drive circuit with a rotation signal Output function and rotation adjustment function.

#### 3. Realization of high response

By adopting the inner rotor type, the starting time is shortened by about 46% compared with the outer rotor type motor of the same class.

Contributing to improvement of mounted products and maximization of operation time.

### [Typical Applications]

Vacuum Cleaner

\*IPM - Interior Permanent Magnet (Magnet embedded type)

Maximum Output	192W (At 19.2V operation)	Size/Weight	Diameter 45.0 X Length 31mm/About 135g
Operating Voltage	192W (At 19.2V operation)	Protect Function	Eddy Current, Motor Lock, Temperature Protection



## Brushless Motor IS-94BZC, IS-92BZC



IS-94BZC



IS-92BZC



Speed Reducer



Controller



Drive Unit

Newly developed IS-94BZC and IS-92BZC are brushless motors for commercial robot (AMR<sup>1</sup>, AGV<sup>2</sup> and the like) and light electric vehicle. Through these new products, Mabuchi Motor is contributing creation of various light electric vehicle application and electrification.

\*1 AMR...Autonomous Mobile Robot "Human coordinated autonomous mobile robot"  
\*2 AGV...Automated Guided Vehicle "Automatic guided vehicle"

### [Product features]

#### 1. Realization of waterproof structure

While motor characteristics are equivalent to those of the conventional IS series, waterproof assurance (IP X 4)<sup>\*3</sup> is realized by adopting a highly airtight waterproof structure around the lead wire.

#### 2. Enhancement of lineup

To accommodate wide range of application, a short type "IS-92BZC" (length: 38mm) which shares parts with IS-94BZC (length 45.5mm) has also been released simultaneously.

#### 3. Enhancement of options

- Speed Reducer: Adoption of a planetary reduction mechanism suitable for high torque. Furthermore, AGF made it possible to hold the radial load directly during loading and conveying.
- Controller: Small size, low electric noise and waterproofing have been realized, making it possible to maximize the characteristics of the motors.
- Drive Unit: Wheel, bracket, electromagnetic brake and the like can be selected.

\*3 It is not adversely affected by water droplets from all directions.

### [Typical Applications]

Commercial robot (AMR, AGV and the like), Light electric vehicle, Power Assist Robot and the like

	IS-94BZC	IS-92BZC
Typical Application	Commercial Robot(AMR, AGV and the like), Light Electric Vehicle, Power Assist Robot and the like	
Maximum Output	680W (at the 36V operation))	450W (at the 36V operation))
Operating Voltage	24V – 36V	24V – 36V
Size	(Dia.) 80.0mm (not including flange portion) X (Length) 45.5mm	(Dia.) 80.0mm (not including flange portion) X (Length) 38.5mm
Weight	About 830g	About 650g





# Corporate Governance

With this concept, we believe that strengthening corporate governance is an essential process of business. We are thus building a transparent governance system based on every principles of the corporate governance.

## Basic Approach to Corporate Governance

At the Mabuchi Group, we recognize that fulfillment of the mission stated in our Management Principle — “Contributing to international society and continuously increasing our contribution” — through our small DC motor business forms the very basis of our existence. Our corporate governance consists of an organizational design to help us achieve the management principle, a business management system, and business policies to maintain them. Therefore, the basic purpose of developing and implementing proper corporate governance is to sustainably increase the profit to all stakeholders including shareholders by creating proper profits and improving corporate values. As a listed company, we believe that building and maintaining the following system is an essential part of proper corporate governance:

- To clearly separate management decision-making and efficient business execution, and to clarify the scope of accountability;
- To build and operate a sound internal control system, namely, to effectively operate the internal control system and the management supervision system;
- To appoint a suitable number of independent corporate officers whose interests do not conflict with those of general shareholders to ensure the objectivity and neutrality of management supervision functions;
- To foster a corporate culture in which all Group employees recognize and share the understanding that the practices of corporate ethics and compliance support the organization’s social impartiality and are fundamental to living up to the trust and expectations of all stakeholders;

and

- To disclose corporate information to stakeholders such as all shareholders in an appropriate, fair, timely and clear manner and to ensure accountability through the Board of Directors, the Audit & Supervisory Committee and other bodies.

## Establishment of a Structure and a System

The Mabuchi Group moved to a company with audit and supervisory committee in which corporate bodies (including independent corporate officers), accounting auditors, and other organizations stipulated by the Companies Act fulfill their respective legal functions. In addition to these organizations, Mabuchi has independently established the Executive Officers Committee, Internal Audit Department (internal audit division), designated committee, compensation committee, and other organizations related to business execution and internal control. With the participation of these organizations, we have established and are operating a Group-wide governance structure and system. At each of our overseas bases, we also conduct internal control through corporate bodies whose existence is required by the laws of the respective countries and through our internal organizations. Through the Mabuchi Group Management Vision, we also share our corporate culture and values globally, and are striving to improve our internal control functions throughout the Group by holding meetings for the management of overseas bases, holding Group-wide meetings, and having the Internal Audit Department conduct operational audits on overseas bases.

## Corporate Governance Structure

(as of 29.March.2019)

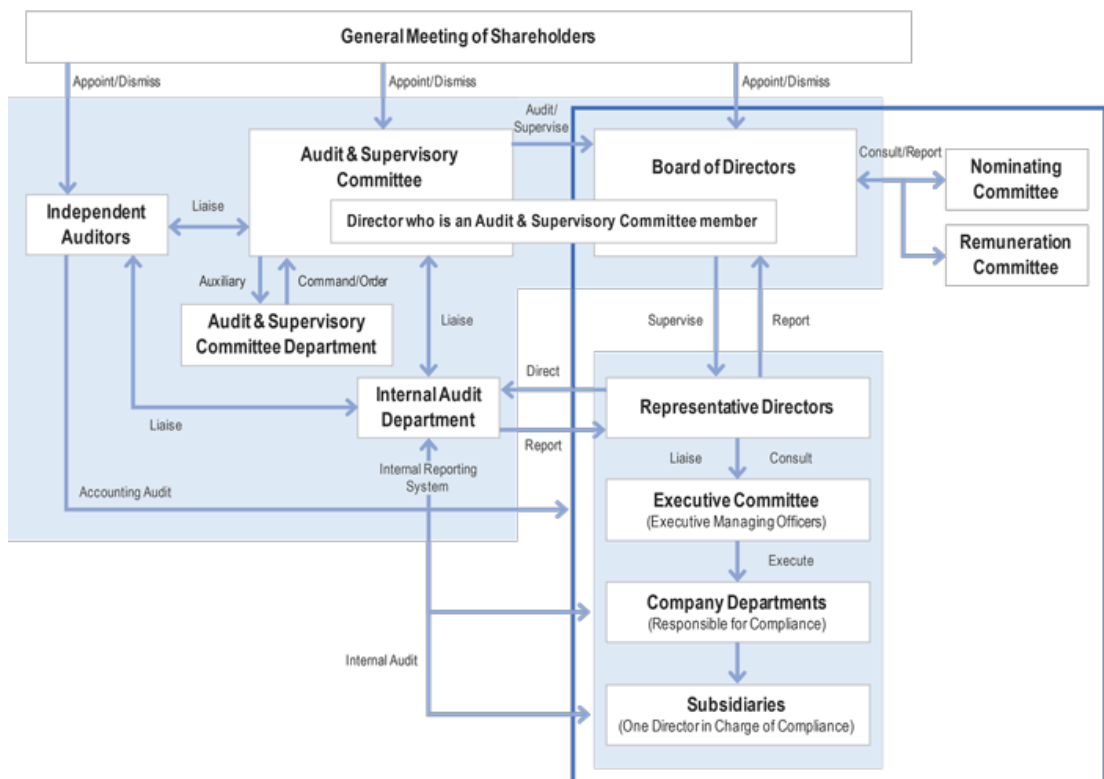

# Compliance

Legal compliance and the maintenance of corporate ethics are social obligations of companies and also the foundation for a company to continue operating and grow. We are strengthening the compliance system so that individual employees understand and comply with this concept.

## Mabuchi Motor Ethical Standard

Mabuchi group sets "Contributing to international society and continuously increasing our contribution" as our Management Principle and conduct business activities to remain true to it. Still, in order to realize this principle, we believe in remaining in compliance with laws and regulations in a given country and region and also to implement activities based on corporate principles that are expected in societies. We thus established the Mabuchi Motor Ethical Standard and presented specific social rules such as laws and regulations that all executives and employees should follow to promulgate them. We compiled the Ethical Standard in a booklet and distributed it to all executives and employees to further improve associated activities and spread the knowledge of it.

Our compliance education activities also continued as required in overseas production bases.

We will provide various study sessions and training programs concerning compliance with laws, regulations, and social ethics to bolster our compliance system.

The director responsible for compliance at each of the Mabuchi Group bases supervises compliance activities of that base under the overall control of the director responsible for internal control at the Head Office. They take a leading role in strengthening internal control and promoting continuous and autonomous compliance activities at each base.

To continuously rectify and improve inadequate points related to compliance activities in the entire Mabuchi Group, the Internal Audit Department conducts periodical and non-periodical audits on all Mabuchi Group bases to examine the conformance to compliance-related rules and procedures as well as acts of ethical violation and reports the results to the top management.

## Ethical Standard Hotline

We have set up the Ethical Standard Hotline in the company to allow all employees to directly inform or consult with the Internal Audit Department about compliance-related information under strict anonymity without using ordinary communication routes (senior managers or existing contact points of each division).

Mabuchi group is always striving to conduct honest and fair business with our suppliers and to build a relationship of trust with them. To address the current social situation, we extended the operational range of the Ethical Standard Hotline to some of our suppliers in addition to Mabuchi employees with a view to preventing problems in advance and strengthening the misconduct-prevention system.

We have also delivered a top management message promising that we will never allow those who have consulted with us to be treated disadvantageously because of their consultation, which is in accordance with the Whistleblower Protection Act.

## Compliance Structure

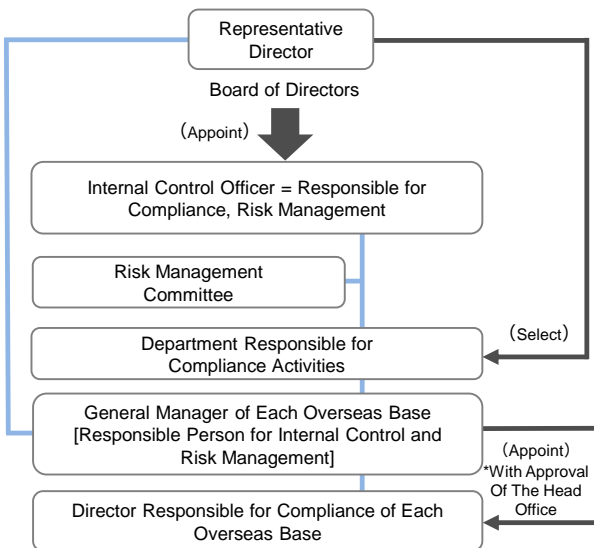

## [Basic Policy of Ethical Standard]



1. All the directors and employees of the Mabuchi Group will put more priority on observing laws, ordinances and rules in the countries and regions where our companies are located as well as international rules than on the profits and the work of our companies.
2. We will strictly refrain from conduct that goes against social ethics by fully recognizing our responsibilities to various stakeholders, including our customers, partners, shareholders, investors, and local communities.
3. We will clearly describe particularly important items among laws, regulations and social ethics in such documents as in-house regulations and make them widely known. All the directors and employees will observe those items sincerely.



# Risk Management

The Mabuchi Group is working on enriching and strengthening risk management for global business activities. The aim is to ensure that the company will be on a long-lasting track for growth, while reducing and minimizing various risks inherent in diversifying business activities.

## Risk Management System

We established the Risk Management Committee to prevent risks from occurring and to minimize damage in the event that a risk has occurred. It is a system that enables us to take the most appropriate response as the entire Mabuchi

Group. We have also prepared a response system, a response policy, and various manuals for times of emergency on the basis of the risk management system.

### Structure of the Risk Management Committee

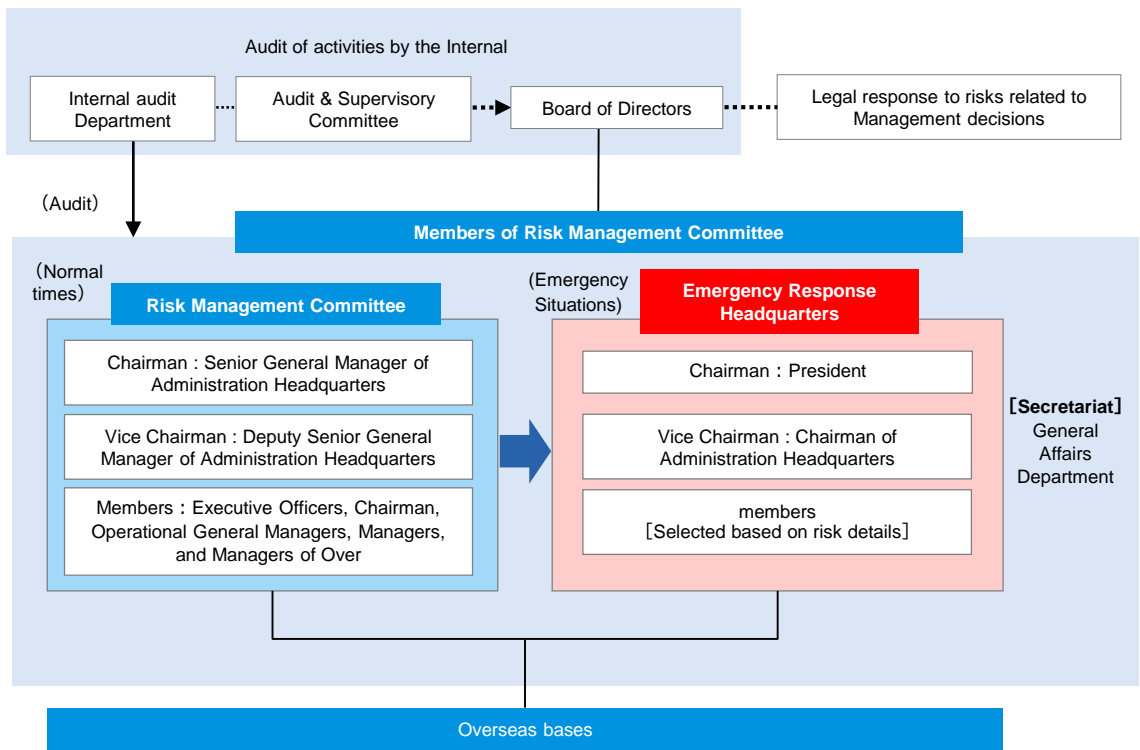

\* General Managers of overseas bases are part-time members  
(Information necessary for risk management is shared on an as-needed basis.)

### Expected risks

[External factors]  
Natural disasters, social crimes, global/political situations, and risks of market uncertainty, including interest rates, currencies, and material prices

[Internal factors]  
Product quality and safety, compliance, information communication systems, intellectual property rights, labor accidents, facility accidents, environment, labor issues, human rights, rumors, suppliers, supply chains, M&A, etc.

### Actions of the members of Risk Management Committee

1. Securing lives (safety) of people
2. Compliance
3. Information security
4. Production and supply shutdown Categorized and specified into

Leader sections are specified for these risks to implement risk management activities as the entire Mabuchi Group while cooperating with the management section and related executive employees.

## Emergency Response Training

In order to ensure safety when disasters and other emergencies occur and to prevent environmental pollution and its spread, we conduct emergency procedure and report drills that assume various cases according to the characteristics of each business.

We prepared and distributed the “Emergency Response Manual for Employees in Case of a Disaster” and “Emergency Response Cards for Large-scale Disasters,” in addition to the “Initial Response and Instructions Manual for Managers.” We also introduced the “Safety Confirmation System (for all head office employees).” Furthermore, a response manual was prepared for each department that plays an important role in the event of a disaster, such as the Emergency Response HQ.



Upper row: Head office  
Bottom row: Overseas bases (Taiwan)

We also educate our personnel about disaster prevention and carry out various disaster drills (drills for evacuation, reporting, fire extinguishing, disaster relief, safety confirmation, and safe return to home) so that employees can calmly take the appropriate action in the event of a disaster.

In addition, we keep in stock disaster supplies such as protective items, equipment, food and drinks, and daily necessities to ensure safety, and accept employees in the company who are unable to return home. The Head Office is able to secure a large amount of drinking water even when the water supply is disrupted because we use groundwater as regular drinking water. We are now preparing to conclude a water supply agreement with the Matsudo municipal government so that we can support the local community's drinking water supply.



Emergency Response Cards for Large-scale Disasters

### Store supplies, materials, equipment, drinking water, and food (Head Office).

- Set up two priority telephone lines in the Head Office building.
- Provide a Personal Handy-phone System (PHS) for emergency use as a means of communication during power outages.
- As measures for power outages, keep an emergency power generator and the fuel necessary for the operation of the Emergency Response Headquarters and the protection of the computer system, as well as emergency toilets.
- Store the helmets necessary for emergency evacuation.
- Stockpile drinking water for those who are returning home.
- Stockpile three days worth of food and drinks as well as water for toilets in case employees are unable to return home.
- Measures to prevent the collapse of facilities, furniture, and equipment
- Equipment and tools that can be used for recovery and urgent repair of facilities, apparatuses, and furniture and to support the affected employees and local communities.

etc.

### Seismic isolation system to protect corporate activities from earthquakes (Head Office)

Seismic isolators and flexible joints are installed to protect the indoor environment even against damage even from large earthquakes of class 7.

## Information Security Policy

Mabuchi group considers it one of our corporate social responsibilities to manage its information assets and information security adequately and to prevent the leak, falsification, loss, and theft of information. Based on this concept, all the employees are deepening their understanding of the necessity of and responsibility related to information security to ensure a high level of information security.

## Privacy Policy

Recognizing that it is an important obligation to adequately handle and protect information that can be used to identify individuals (hereinafter referred to as “personal information”), Mabuchi group will strive to protect personal information based on “Privacy Policy”.

# Supporting Local Communities

The entire Mabuchi Group has continuously been conducting various community activities including an activity to protect the environment and social and welfare activities.

## The Head Office is aiming to coexist with local communities.

The Head Office has an on-site Bio Garden to convey the concept of coexistence with the local community. Every year, migratory birds visit its gentle waterscape and field.

Vegetation management is still continuing today, 15 years after the construction of the building. Such management improves the regional environment by rebuilding vegetation that is unique to the region for biodiversity and eliminating alien species.



(Head Office)

## Supporting Local Communities

We continuously visit and make donations to children's homes and elderly care homes to extend a helping hand.

In 2018, employees of America Mabuchi gave donations and Christmas presents to families in need of financial support.



Donation Activity (Dalian Mabuchi, Kaohsiung Mabuchi, Danang Mabuchi, America Mabuchi)

### Afforestation, beautification and cleaning activities

We are continuing to beautify and clean up the area.



Clean-up activities (Ludong Mabuchi, Kaohsiung Mabuchi, Dalian Mabuchi)

### Donating Blood Activity

Mabuchi employees at the Head Office and other locations are actively cooperating in donating blood as a Group-wide activity. The Head Office has been receiving a letter of appreciation from the Red Cross Society every year.



Donating Blood Activity (Taiwan Mabuchi)

# Support for Manufacturing / Education

Mabuchi aims to contribute to the development of society by extending various types of support to local communities and international society. As one such activity, we provide educational support to the young people who will lead the next generation to help them grow up surrounded by the joy of science and manufacturing.

## Sponsoring Robot Contest

Mabuchi has been co-sponsoring the National Technical College Robot Contest and the ABU Robot Contest and the College Robot Contest by providing motors and funds for them. We support these events in the hope that we can help to foster future engineers and develop science and technology.

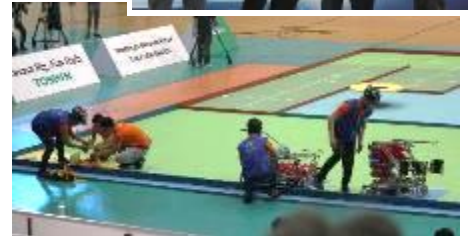

National Technical College Robot Contest

ABU Robot Contest

## Providing Motors

Support for National Technical College Robot Contest About 24,000 motors in total



RS-555VC with gear head (top)      JC/LC-578VA  
RS-385PH with gear head (bottom), etc.

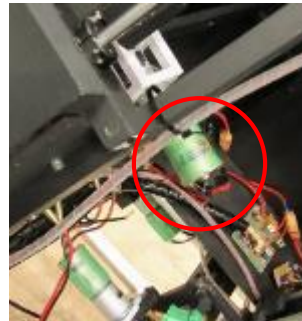

## We are teaching the fun aspects of science to children.

### Visiting classes

We have been sending our head office employees to elementary schools in the area (Matsudo City, Chiba Prefecture) as science instructors every year. We have received comments from children, who received classes using science teaching materials developed independently, saying things such as they found science to be fun as they experimented with magnets using motor components.



Classes held in a local elementary school (Head Office)

### Exhibition and Support for Events at the Science Museum

Mabuchi has been presenting a permanent exhibition at the Science Museum (Chiyoda-ku, Tokyo) to support scientific education for young people. Displays include an explanation on the mechanism of motors, various motors used in daily lives, and handicrafts powered by a motor. And, every autumn, we offer a science experiment class in collaboration with the Museum.



Science experiment class in the Science Museum (Head Office)

## Workplace Experience and Company Observation

Head office takes in local elementary school students in cooperation with the career education programs at their schools. Also, our overseas bases are also inviting local students and family members of the employees to observe workplaces.



Observation by elementary school students (head office)



Observation ceremony by employee's family (Jiangsu Mabuchi)

## Education support by overseas bases

Our overseas bases continuously provide educational support to children who will be responsible for the future by donating learning materials such as books and writing materials.



(Wafangdian Mabuchi)

## Support to Kashiwa Reysol Academy as a sponsor

As part of our local community contribution activities, our head office concluded a uniform sponsorship agreement with Kashiwa Reysol Academy established as an organization for helping human resources to become football players of Kashiwa Reysol, a professional football team. It also supports the development of young people.



## Internship Program

Through our internship program, we continuously accept domestic and overseas students as interns to give them an opportunity to deepen their understanding of Mabuchi's philosophy through actual work.



## Enjoying manufacturing with children!

### Summer Vacation Handicraft Class

We hold the "summer vacation handicraft class for parents and children" every year for fourth through sixth graders living in the area around the Head Office (Matsudo City, Chiba Prefecture). We are going to continue this handicraft class so that more students can enjoy the pleasure of creating something.



Motors for craft

### Wooden craft events

In addition to summer vacation classes, children enjoyed wooden crafts using our motors at the Shizuoka Hobby Show in May and at the Chiba Museum of Science and Industry in late August.



Handicraft event at Shizuoka Hobby Show

# Creating Lively Workplaces

## Work-life Balance

We are striving to create an environment in which employees can lead a flexible life at various stages of their lives, such as child-raising and middle-aged or elderly stages, both at home and in the community while continuing to work with a sense of fulfillment at the company.

We are promoting family-friendly policies such as setting longer childcare leave than legally designated and starting a short-work-hour system for employees raising small children. We are also participating in Chiba Prefecture's "Lively Employees! Energetic Company Declaration" program.

The Chiba Labor Bureau recognizes the company as a "Complying Business" under the Act on Advancement of Measures to Support Raising Next-Generation Children. The company received the next-generation certificate symbol, "Kurumin."



To build an employee-friendly environment

- Parental leave (three years) / Nursing leave (one year)
- Support for self-improvement during nursing leave and parental leave
- Leave for childbirth by spouse: Acquisition rate 100%
- Low-interest loans for fertility treatment
- Short working hours and exemption from overtime work for parental and nursing leave
- Encouragement for employees to take paid leave
- Enrichment of welfare facilities
- Telework system, etc.

## Promoting Employment of Persons with Disabilities

The Head Office and the entire Group are promoting the employment of persons with disabilities. The aim is to realize a society in which they can work based on their ability and aptitude and lead an independent life in the community in the same way as persons without disabilities.

## Keeping a Healthy Body and Mind

We believe that employees' healthy bodies and minds are the base of their good social life and the source of Mabuchi's vitality. Therefore, we started a mental health program at the Head Office more than 20 years ago that includes mental health checks, care given by in-house counselors, and mental health seminars. In fiscal 2018, we featured an article by an outside counselor in our company newsletter and explained to our employees about "mental health".

### Corporate award for workers

Dalian Mabuchi received an award from the Bureau of Human Resources and Social Security of Dalian for continuing the implementation of social and medical insurance measures.



Based on one of the business foundations, "to position people as the most important business resource and effectively utilize them through work and nurture people who are useful for society", we are striving to create a stimulating work environment at every workplace and encouraging them to pursue self-development and self-fulfillment individually and feel worth working.

## Personnel Performance Evaluation System and Self-assessment System

Mabuchi group's personnel evaluation system is aimed at ensuring the mutual growth of the company and employees by correctly identifying the contributions of all the employees that play a wide variety of roles in the company. We positively use the system not only as a management tool but also as a way to develop human resources.

In addition, we consider that the right person in the right place and the creation of a positive work atmosphere are very important. With this in mind, we have employees periodically carry out self-assessment to grasp their awareness of work.

## Discretionary labor system

The head office applies a discretionary labor system only to employees who meet certain criteria after obtaining the recommendation of their superiors and their consent. By setting the applicable work for each department, it became possible to choose a way of working that is different from the conventional time-based work style.

## Employee award system

The Mabuchi Group has an award system to recognize employees who have made great contributions to the company, demonstrated outstanding performance in sales activities, proposed improvement plans, exhibited commendable behavior not only at work but also in society, or contributed to the local community.



## Health promotion day setting

With the aim of preventing and improving lifestyle-related diseases of employees, we set the second Wednesday and the last Friday as "Health Promotion Day" every month, and doing the following activities:

- Improve eating habits by adjusting the amount of food and having a well-balanced menu
- Health promotion to start from walking (promote use of stairs by operate only one elevator out of 3 elevators of head office)
- Take adequate rest both physically and mentally (encourage employees to leave by 17:00 on The health promotion day)
- Promote the habit of quitting smoking and setting days of no drinking alcohol



Healthy plate full of vegetables of the employee cafeteria





## Educational Support and Qualification Incentive System

### ◇ Support for English Learning

The Mabuchi Group is implementing the following programs to build a company-wide environment for employees to learn languages (especially English) so that employees can be active globally.

- Providing opportunities for people to take the TOEIC · CASEC test
- Holding TOEIC classes
- Providing opportunities for people to use an online English conversation system
- Running a short-term overseas study program
- Implementing a trainee system, etc.

### Qualification Incentive System

Head office is promoting employees' self-development by establishing the Qualification Incentive System with a view to creating a self-learning atmosphere in the company and encouraging employees to acquire a wide range of knowledge useful for business operations.

Also, the Mabuchi Business School (home study system) is held twice a year, and the cost of the education is reimbursed to those who complete the program so as to create an environment where more employees can actively learn on their own.

### Self-Access Learning (SAL) Room, Library Corner Biblio

The in-house Self-Access Learning (Internal Name :SAL) Room was established for employees to learn foreign languages and study for certification tests based on their own goals and levels, as well as to have group discussions. Individual employees use this area for self-improvement during break time as well as before and after work hours.

The in-house library corner (Internal Name: Biblio) was also established to support employee learning. Employees can borrow any great works.



Recommendable books are introduced every month in front of the canteen.



### Training for employees to learn and grow

Mabuchi group regards its training system as one of the processes for employees to gain a self-regulating mindset and spontaneously learn and grow. Mabuchi group is providing training from various perspectives targeting every position from executives to new employees. In 2018, training session was held to discuss life events unique to women and the way they work after the events.



## Skill Competition

Representatives of individual production bases of the Mabuchi Group gather for a work skill competition. With similar events held at individual bases, employees are addressing to improve their skills through competition.



Skill competition (Head Office)

## Various Events for Employees and Families

### Head Office

We hold a variety of events such as garden parties and bowling tournaments by teams of departments to enhance communication and build a sense of unity among head office employees.



Bowling Tournament



Garden Party

### Overseas bases

Many events participated by employees at overseas bases are held regularly, including sports festivals, company trips, and cultural festivals.

Dalian Mabuchi participated in a sports event sponsored by Dalian Sports Federation in December 2018 and won fifth prize in three-man football.



Representative players were selected from all bases of the Mabuchi Group in China, and a badminton event was held in Dongguan City, Guangdong Province.



Every year, Mabuchi Europe participates in the Marathon events as a team.



# Environmental Management

We obtained the certification of "Environmental Management System ISO14001" at the Head Office and individual production bases. and obtained the certification. And, we set environmental targets to be achieved by individual departments and bases, the Head Office and the Mabuchi Group, implement through PDCA management and make positive efforts to work on environmental management. Our improvements of the environmental management are and will be expedited to perform high-level environmental conservation activities.

## Environmental Management System

The environmental management system of the entire Mabuchi Group is supervised by a Environmental Representative. The Environmental Management Committee is established at the Head Office. This committee is comprised of the chairman, who is the Environmental Representative, chairmen and general managers of individual departments. They discuss and determine the Mabuchi Group's environmental policy, objectives, and measures to be taken. Also, we have set up the Chemicals Task Force and the Energy Saving Task Force under the Environmental Management Committee. Those task forces propose measures in each specialized area and promote environmental preservation activities.

## Environmental Audits

Conformance of Mabuchi group environmental management system to the ISO requirements and the current effective management status of the system are periodically audited by an external certification body (third party) and the internal Audit Department. Through these audits, we maintain and improve the level of our environmental management continuously.



Internal environmental audit (head office)

## Environmental Management Organization

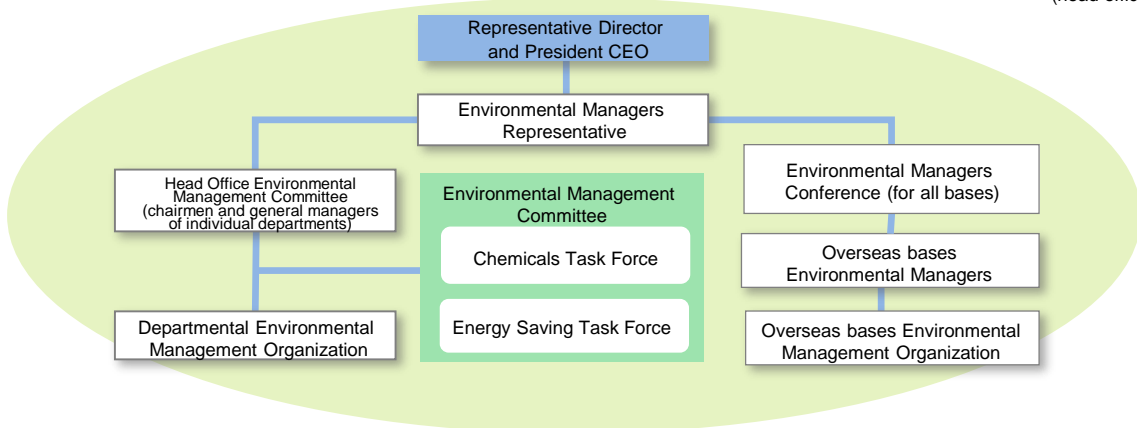

## Environmental policy of the Mabuchi Group

We carry out our corporate activities without sacrificing the environment or human health. We also strive for continuous improvement through our environmental management system, and aim at achieving a sustainable society.

1. We observe environmental laws and regulations, and make diligent efforts to prevent pollution. We are always aware of the impact that our business activities have on the environment, and manage the impact by establishing our own standards.
2. In order to reduce environmental impacts associated with our business activities, we focus on the following:
  - 2.1 In order to reduce CO2 emissions and to effectively utilize limited resources, we actively work on energy saving, resource saving, recycling, and waste reduction.
  - 2.2 In our products and production processes, we thoroughly manage any substances of concern and seek to switch to equivalent alternative substances as much as possible.
  - 2.3 We perform green procurement activities positively using environmentally friendly parts and materials.
  - 2.4 Being aware that the protection of biodiversity is a significant corporate objective, we promote eco-friendly approaches.
3. In order to raise the environmental awareness of all our employees, we actively conduct environment-related educational activities.
4. We familiarize all of our employees with this environmental policy, and announce the policy to outside parties.

Mabuchi Motor Co., Ltd.  
Representative Director and President CEO

**Hiroo Okoshi**

Established: September 27, 1998, Revised: March 28, 2013



# Green Procurement

By setting Mabuchi group's own special evaluation criteria in addition to laws, regulations, and customer requests, we at Mabuchi strictly control environmentally prohibited substances designated in those standards so that they will not be included in materials and parts of products that we procure from our suppliers. We also prioritize the use of materials and members with a lower environmental impact.

## Promotion of Green Procurement

Our own environmental conservation efforts are not enough for developing products with a low environmental impact throughout the life cycle of products, ranging from the extraction of material resources, production and processing, distribution and sales, consumption and uses to disposal and recycling. Thus, we also evaluate the environmental efforts of our suppliers to reduce environmental impact and avoid environmental risks.

We make it a rule that suppliers must follow the green procurement procedure shown in the flowchart below and submit documents certifying that environmentally prohibited substances are not contained in their raw materials and parts, in addition to an environmental activity survey sheet.

## Compliance with Laws and Regulations

In addition to the European RoHS Directive, the European ELV Directive, the European REACH Regulation · Substance of Very High Concern (SVHC), Japan's Chemical Substances Control Law - Class 1 Specified Chemical Substance, the Global Automotive Declarable Substance List (GADSL), other regulatory requirements, customer requests, Mabuchi voluntary standards, etc., we are taking action ahead of time by adding regulated substances and changing the prohibition rank, for example.

As conflict minerals are a source of monetary funds for armed groups, we are requesting our suppliers not to use them and also reporting the results of conflict mineral investigation to our customers.

We are closely communicating with our suppliers on a daily basis and actively auditing the uses and storage conditions of environmentally hazardous products. Thanks to these efforts, we have experienced no environmental accidents since the enactment of the 2006 RoHS Directive in Europe up to now.

We will continue to promote green procurement activities with our customers and suppliers.

Green Procurement Flowchart

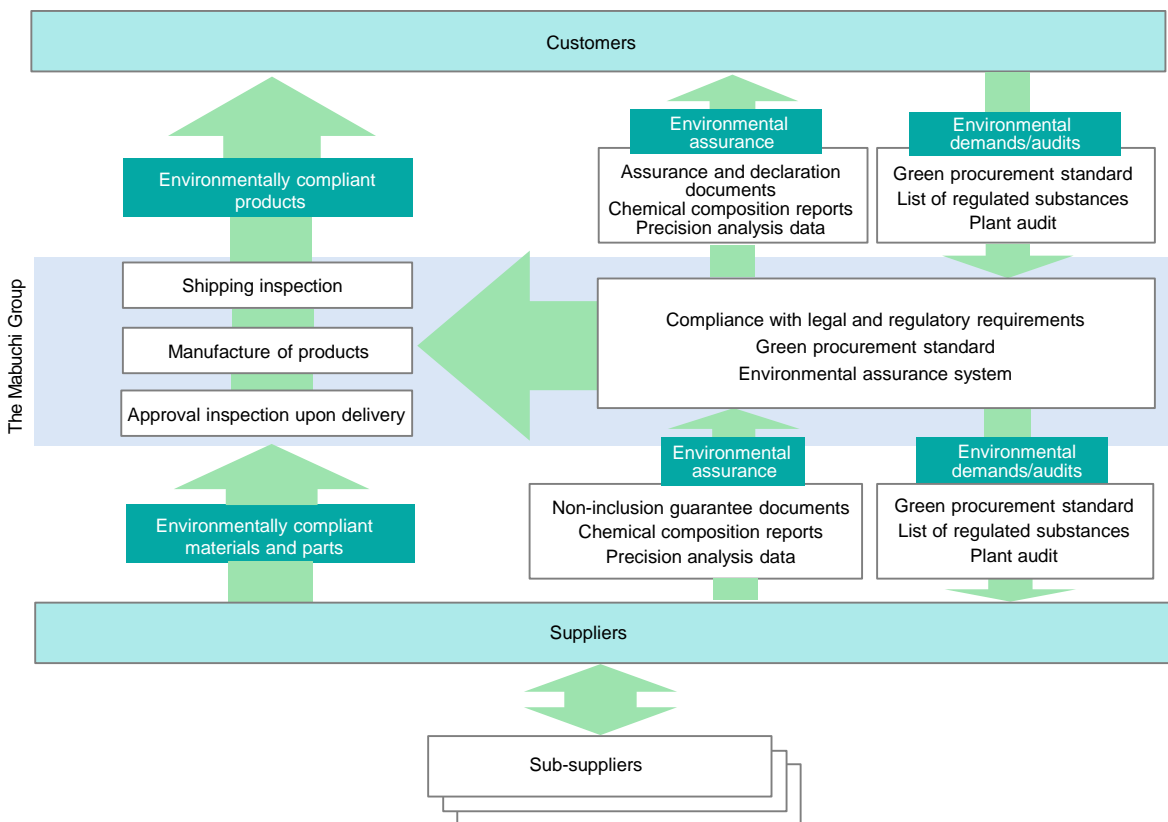

# Environmental Communication

By providing wide-ranging information on Mabuchi group's environmental way of thinking and environmental management activities to parties both inside and outside the company to raise the environmental awareness of our employees, Mabuchi group gains a broad social understanding of our approach to environmental conservation and related activities.

## Publication of Social & Environmental Report and Environmental Information on Our Website

We will continue to be fully accountable for our CSR approach and the results of our activities through the publication of the Social and Environmental Report on the company website. Also, we will further improve communication with all stakeholders.

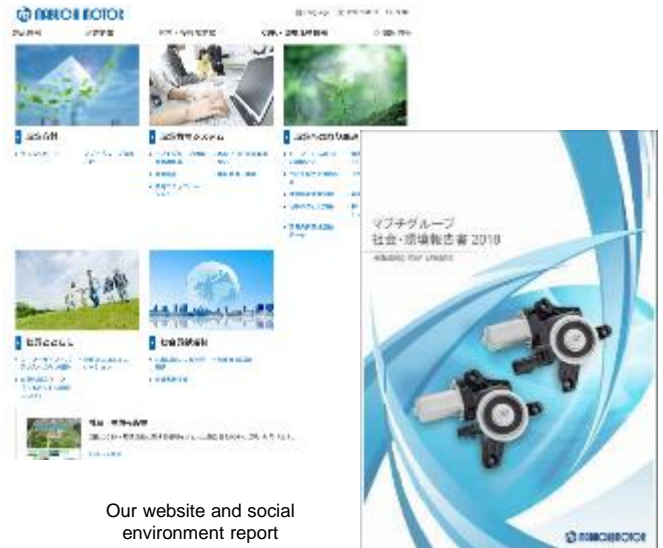

Our website and social environment report

## Environmental Communication to Communities

To efficiently implement environmental conservation in the entire Mabuchi Group by sharing environmental information, the Environmental Managers Conference has been held every year with the participation of environmental managers from the Head Office and overseas production bases.

Our intranet has a database called "ECOLOG" containing environmental information so that our employees can share a broad range of environmental information with each other. We also publish feature articles on environmental information in our company newsletter to introduce the present status of Mabuchi's environmental activities and the latest environmental information. The aim is to increase the environmental awareness of employees.



Environmental Managers Conference was held to connect multiple bases via video conference

## Environmental education

In order to enhance the environmental awareness among our employees, we are implementing environmental lessons according to specific goals.



Waste sorting lesson

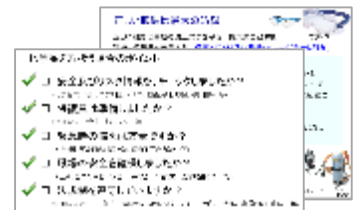

Educational materials about the handling of chemicals

## Environmental Slogan and Poster Contest

To improve the environmental awareness of employees, the Environmental Slogan and Poster Contest is held yearly as a Group-wide event. This year, a total of over 10,000 works were submitted from our Head Office and overseas bases, and about 117 were selected to move on from the first screening process to the second. Award-winning works selected in the second screening process were displayed in the cafeteria of the Head Office to further increase environmental awareness.

### [1st place in Slogan Category]

「轻量化, 节约化, 零不良化, 追求资源效益最大化, 万宝至永不止步。」

(Weight reduction, omission, zero defects, resource efficiency maximization, Mabuchi will not stop its course)

(Environmental Poster 1st place work)



(Environmental Poster 2nd place work) 2 works



## Safety Awareness Poster Works Contest

The "Safety Awareness Poster Works Contest" was newly held from 2018. Under the theme of alerting to work-related accidents, 55 works that have passed the primary screening from the head office and overseas bases are finally judged, and 14 works are posted on the company intranet as award-winning works.

(Safety Awareness Poster 1st place work)



(Safety Awareness Poster 2nd place work) 2 works



## Environmental Activities

- 1993 - The Management Guideline “Conduct corporate activities which preserve the earth’s environment and protect human health” was explicitly stipulated.
- 1997 - The Environmental Management Committee was established to take specific measures against environmental problems.
- 1998 - Mabuchi Group’s Basic Environmental Policy was established.
- 1999 - ISO 14001 Certification was acquired.
- 2000 - Green procurement activities started. Selection and evaluation of alternative materials for the production of cadmium-free motors were completed.
- 2001 - Publication of the Environmental Report was started. Preparations for the commercial application of lead-free soldering were completed.
- 2002 - Shipment of hexavalent chromium-free sample motors was started.
- 2004 - The new Head Office building incorporating advanced energy-efficient technologies was completed.
- 2006 - The production policy was switched to the production of motors complying with the EU’s RoHS and ELV directives, and a green procurement explanatory meeting was held at all production bases.
- 2008 - “Environmental Report” was renamed “Social & Environmental Report” (to contain the information on our social activities).
- 2012 - The Basic Environmental Policy was revised and established as “the Mabuchi Group Environmental Policy.”
- 2015 - The construction of our new environment-friendly plant “Mexico Mabuchi” was completed.
- 2018 - Completed construction of our new environment-friendly plant, Poland Mabuchi
- 2018 - An ISO 14001 certification was obtained at Mexico Mabuchi

## Report of Environmental Data

	Unit	2014	2015	2016	2017	2018
Amount of electricity purchased	(10,000 kWh)	17,331	18,388	17,718	19,842	19,902
Amount of CO <sub>2</sub> emissions	(t- CO <sub>2</sub> )	85,860	88,196	93,635	98,529	98,275
Waste generated	(t)	1,503	1,273	1,297	1,381	1,494
Water usage	(1,000 m <sup>3</sup> )	886	815	816	814	796
Volume of coal used	(t)	1,650	0	0	0	0

These data are computed based on the data of Mabuchi Motor’s Head Office and major overseas production bases.

Issued: May 2019

< Contact >

Mabuchi Motor Co., Ltd.

Administration Headquarters, General Affairs Department

〒270-2280

430 Matsuhidai, Matsudo-shi, Chiba-ken, 270-2280 Japan

TEL:047-710-1111

